



Technical Information

Colour Specifications



Colours may not appear exactly as shown. Contact your authorized Vista dealer for proper colour samples. Please note an additional charge applies to our designer and custom colour program(s).

In addition to our seven standard colours, Vista offers a Premier line of popular architectural colours. Alco has worked closely with other leading producers of exterior finishes to develop the Diamond Series of colours. These 35 popular architectural colours enable any Vista project the affordability to coordinate railing colour with its setting, producing a truly outstanding result. Custom Colours are also available.

Coating Process

Vista uses the latest technology in aluminum alloy and exterior metal coatings available. While many coating used on other systems have been designed for interior applications, Vista's materials and processes have been specifically designed for use outdoors. This ability to resist weathering and ultraviolet damage allows our Powder Coated finish to meet one of the toughest architectural standards in the industry, the AAMA 2604.

The critical process! Pre-treatment of the aluminum, application and the proper curing of the powder coat finish are critical. If any of these processes fail, the finish will peel, chip, and flake off. We electro-statically apply our powder coat finish in-house. Our Q-base quality system mandates daily testing to ensure the adherence and cure of the finish.

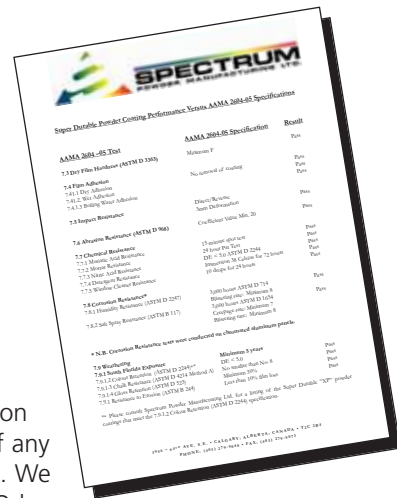

Please note that aluminum has characteristics that are not suitable in corrosive environments (ie. marine, or seashore applications).

Quality



The Q-Base Quality Management System - ensures consistent quality standards are met. Alco was certified under the Q-Base Management System in 1996 and continues to operate under its certification. Alco's compliance to these standards are confirmed every six months through an independent audit process.

Engineering

The Vista Aluminum Railing System is engineered to meet all major U.S. and Canadian building code requirements. Please refer to Vista's Design Manual for further details.

Warranty

Vista offers a limited lifetime residential warranty against defects and workmanship. Ask your Vista Dealer for details or refer to our warranty information online at <http://www.alcoventures.com/vista/warranty.asp>

Technical Mounting Applications

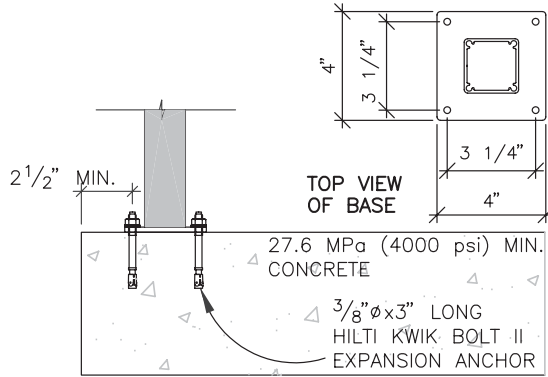

1 1/2" OR 2" POST
TOP MOUNT TO CONCRETE

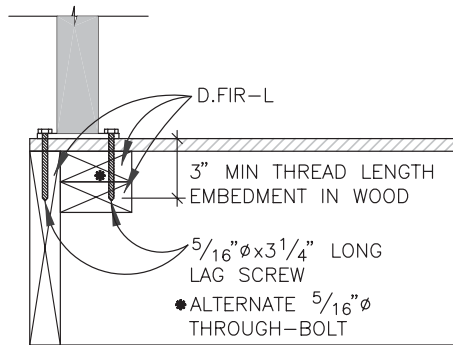

1 1/2" OR 2" POST
TOP MOUNT TO D.FIR-L WOOD
FLOOR JOISTS PERPENDICULAR

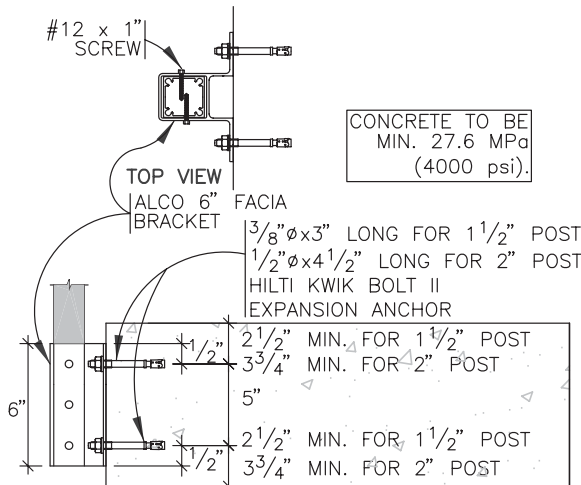

1 1/2" OR 2" POST
SIDE MOUNT TO CONCRETE

Anchorage

Proper anchorage of guardrail posts and rails to a sound and structurally adequate supporting structure is essential for a guardrail system. These elements must be as secure and rigid as possible. A structurally adequate supporting structure is as important as the anchorage elements themselves. One without the other compromises the load carrying capacity and performance of the guardrail system. **Building designers and general contractors must be made aware of their responsibility to provide for proper support conditions since this is beyond the normal scope and control of the guardrail system designer and installer.** The adjoining figures indicate some common and approved post base and rail connections. For comprehensive engineering information on Vista products, please consult with your Vista Dealer.

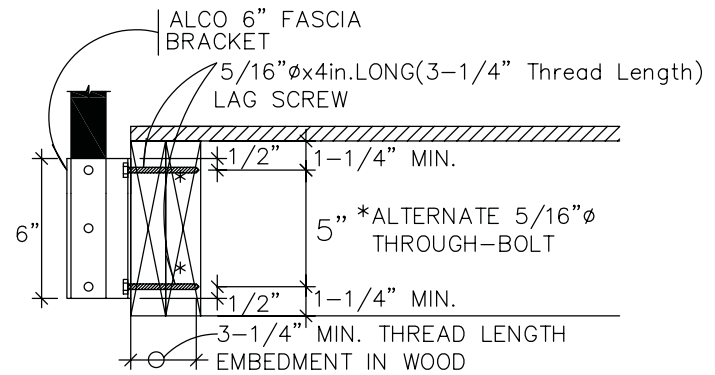

1 1/2" OR 2" POST
SIDE MOUNT TO D.FIR-L WOOD
FLOOR JOISTS PERPENDICULAR

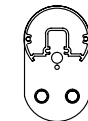
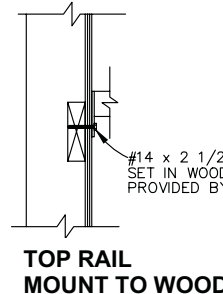

TOP RAIL END CLIP

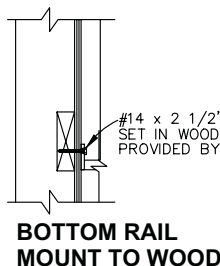
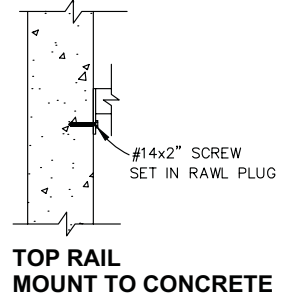

BOTTOM RAIL END CLIP

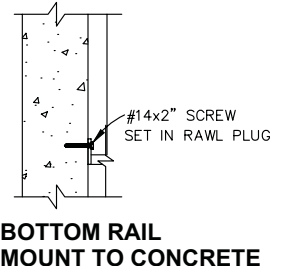

The information contained in this drawing is the sole property of Alco Ventures Inc. Any reproduction in part or as a whole without the written permission of Alco Ventures Inc. is prohibited.

The above are examples of approved mounting situations using specific fasteners. Alternate fasteners may be used in their place provided equivalent service loads are met. For more comprehensive engineering information, please consult with your Vista Dealer.

Your authorized **VISTA** dealer

